

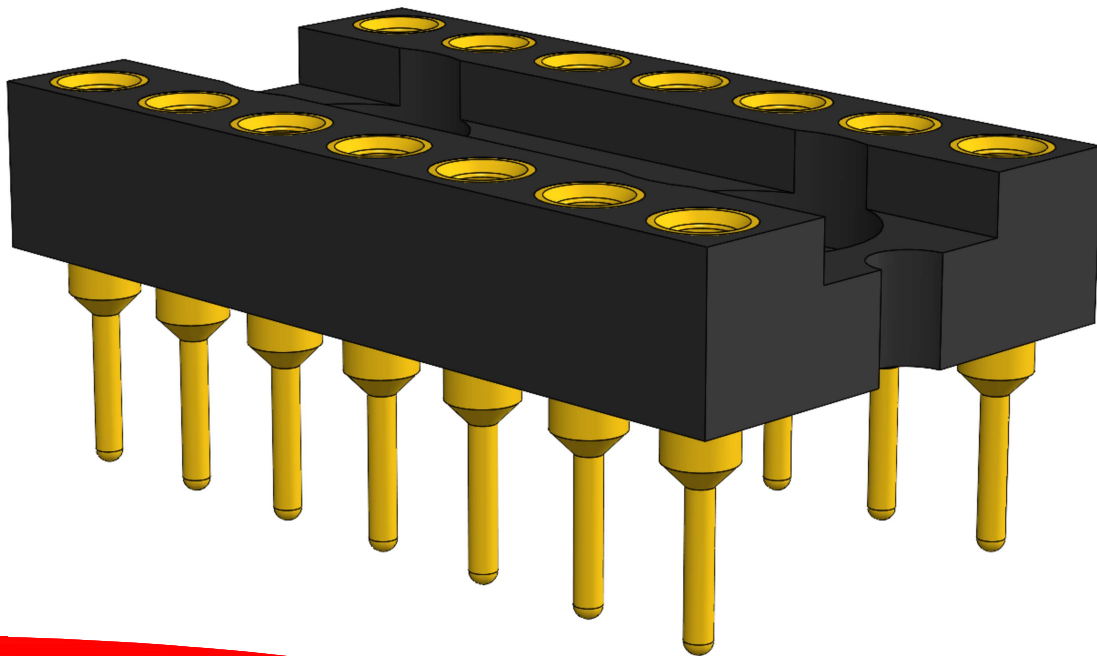

High-Reliability Optoelectric Sensor Sockets for Inphenix, Inc.

INPHENIX



Featuring Andon's Unique SenstacTM Contact

INPHENIX, Inc.
14 PIN BUT
IPDFDXXXX BUT
IPFPDXXXX BUT
IPFPTXXXX BUT
IPNLDXXXX
IPRADXXXX
IPSDDXXXX BUT

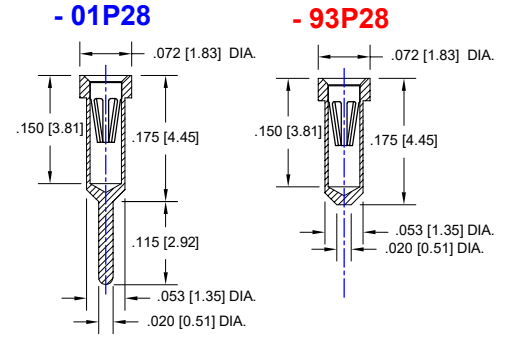
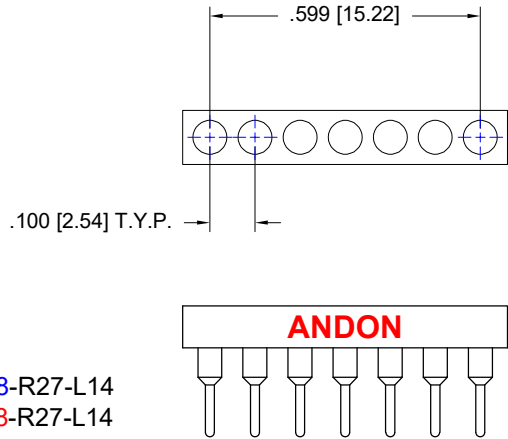

Thru-Hole: C10-007-07-01-01P28-R27-L14
Surface Mount: C10-007-07-01-93P28-R27-L14

INPHENIX, Inc.
14 PIN DIL
IPDFDXXXX DIL
IPFPDXXXX DIL
IPFPTXXXX DIL
IPSDDXXXX DIL

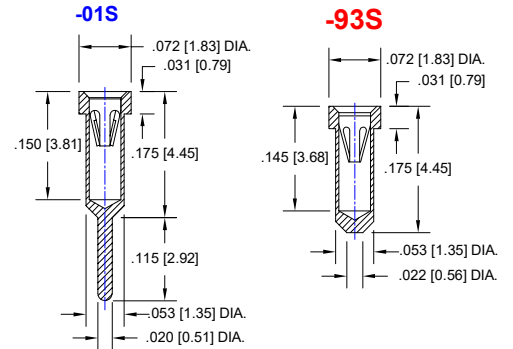
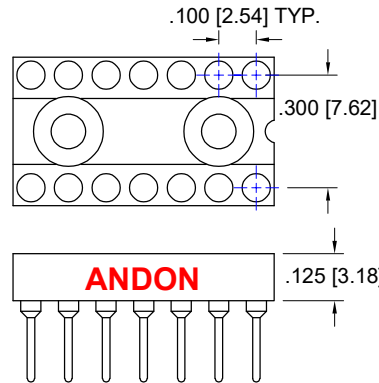

Thru-Hole: 201-314-01S-P15-B10
Surface Mount: 201-314-93S-P15-B10

INPHENIX, Inc.
8 PIN BUT
IPSDDXXXX BUT

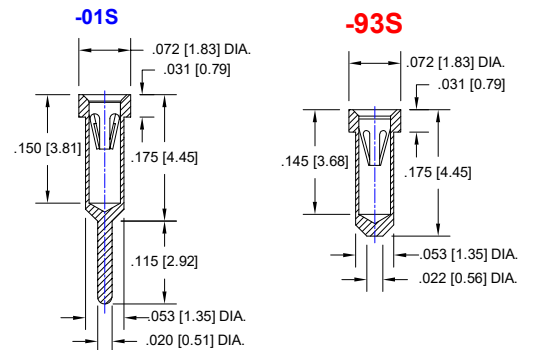
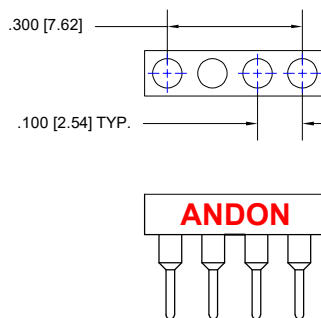

Thru-Hole: C10-004-04-01-01S-R27-L14
Surface Mount: C10-004-04-01-93S-R27-L14

Heat sink socket available to reduce heat and noise. Contact Andon for details.

INPHENIX, Inc.
TO5/TO9/TO39
IPSDTXXXX-TO 8
IPSDTXXXX-TO 9
IPSDTXXXX-TO 39

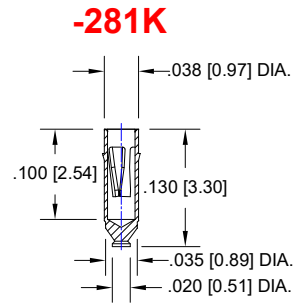
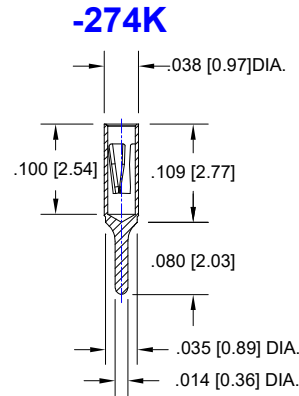
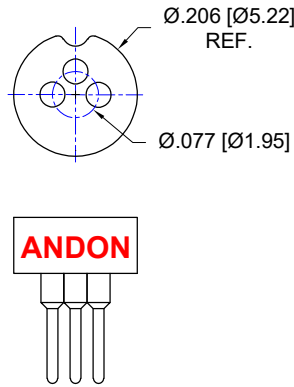

Thru-Hole: R076-0403-01N-274K-R27-L14
Surface Mount: R076-0403-01N-281K-R27-L14

INPHENIX, Inc.
TO56 HEADER
IPSDTXXXX-TO 56

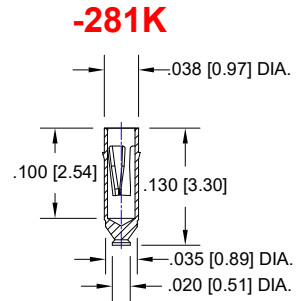
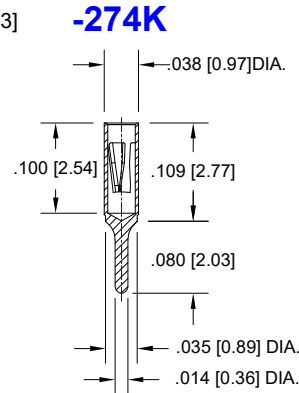
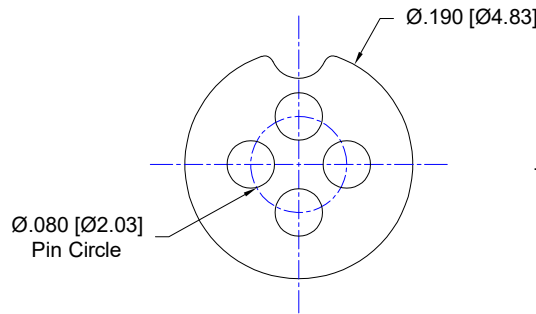

Thru-Hole: R080-0404-01N-274K-R27-L14
Surface Mount: R080-0404-01N-281K-R27-L14

Technical Information

Material:

Insulator: Hi-Temp UL 94V-O
Terminal: Brass, per ASTM-B16
Contact: BeCu, Per ASTM-B194

Plating: RoHS COMPLIANT
R27 TERMINAL: GOLD / CONTACT: GOLD
OTHER PLATINGS AVAILABLE

Terminal Acceptance and Forces							
Thru Hole Socket Terminals				Surface Mount Socket Terminals			
Thru Hole Terminal	Accepts Pin Diameter	Insertion Force	Withdrawal Force	Surface Mount Terminal	Accepts Pin Diameter	Insertion Force	Withdrawal Force
-01S	Ø.018 [Ø0.46]	9.0 oz Avg.	2.0 oz Min	-93S	Ø.018 [Ø0.46]	9.0 oz Avg.	2.0 oz Min
-274K	Ø.018 [Ø0.46]	1.0 oz Max	0.5 oz Min	-281K	Ø.018 [Ø0.46]	1.0 oz Max.	0.5 oz Min
-01P28	Ø.028 [Ø0.71]	.70 oz Max	0.35 oz Min	-93P28	Ø.028 [Ø0.71]	.70 oz Max	0.35 oz Min

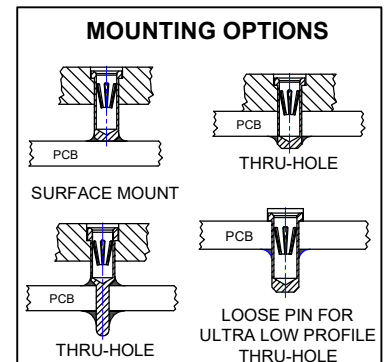

Andon Proprietary Information
RoHS Compliant

*Sockets are not drawn to scale Inphenix, Inc. 05/12/2026

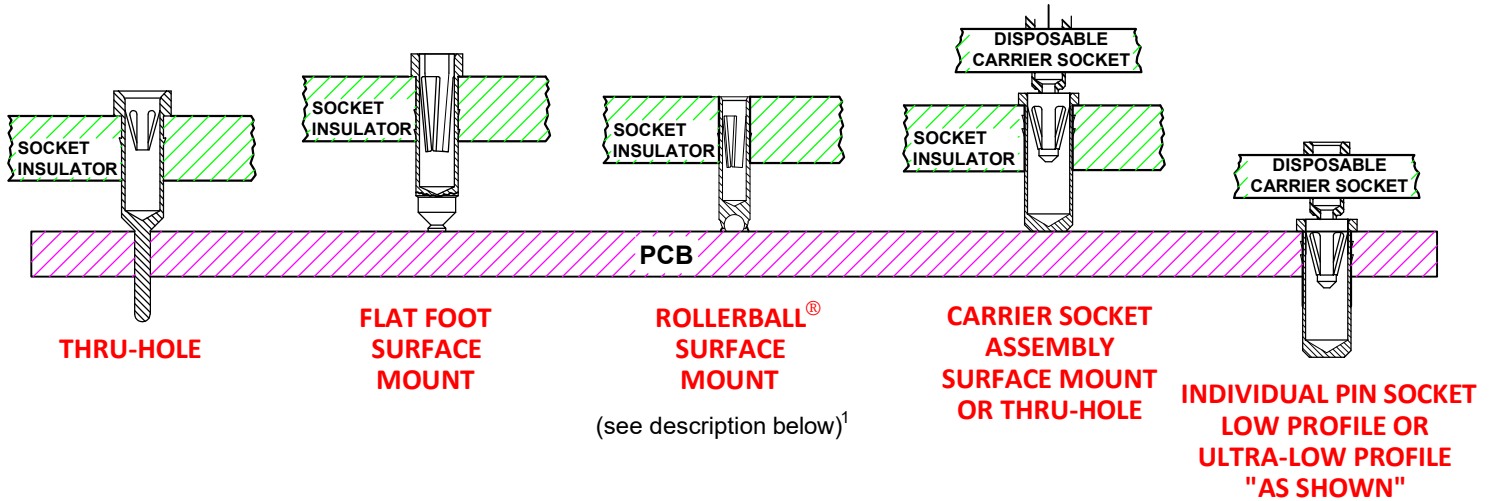

¹Andon's patented Rollerball[®] socket terminal option provides more accurate soldering, a stronger connection, and improved electrical connectivity - especially under shock and vibration - than other solder ball terminal designs. Better yet, it can enable you to avoid expensive rework and scrap - especially with larger PCBs where coplanarity is an inherent challenge.

The bottom of these terminals has a radiused hole, to prevent gas entrapment. The terminal is crimped over the solder ball beyond its hemisphere, encapsulating it - leaving just enough of the solder ball exposed to provide sufficient solder without the solder bridging common in conventional solder ball terminal designs.

With this unique design, the critical distance between the terminal and the PC board pad is typically reduced from .036"-.040" to .018"-.022". As such, the solder becomes part of the "anchor" cross-section - providing additional mechanical strength to the connection, as well as improved electrical connectivity. Because it also provides controlled dispersion of solder, this encapsulated solder ball reduces the risk of solder bridging inherent in conventional solder ball terminal designs.

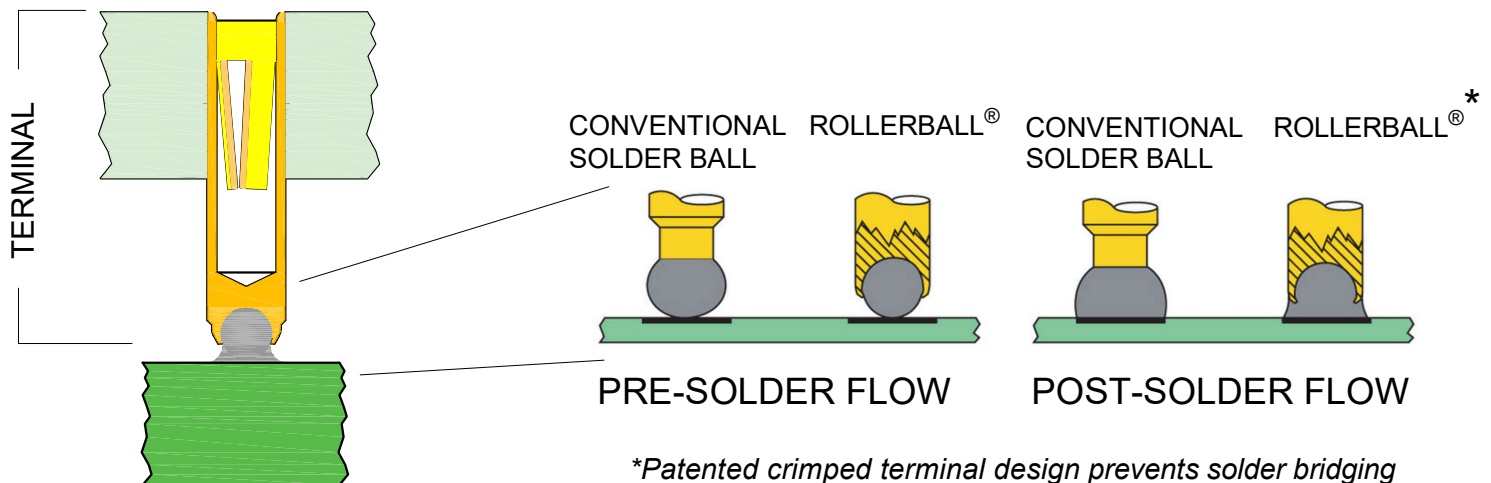

For fast, accurate placement of SIP sockets and ultra-low profile terminals

Phase 1:
Receive Carrier Assemblies designed to your pin layout.



Phase 2:
Place carrier assemblies onto PCB; run through your soldering process.



Phase 3:
Remove carrier and plug in your device; discard carrier or send back to our factory for reloading.

DIP

Before Soldering

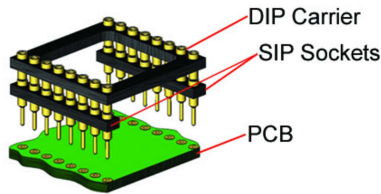

During Soldering

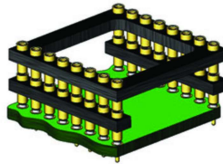

After Soldering

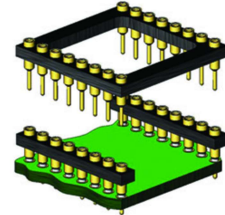

ULTRA-LOW PROFILE SIP

Before Soldering

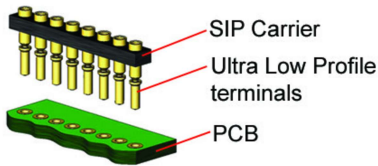

During Soldering

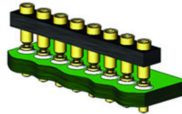

After Soldering

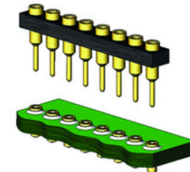

ULTRA-LOW PROFILE PGA

Before Soldering

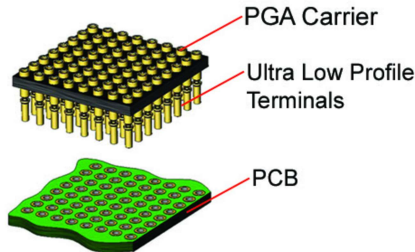

During Soldering

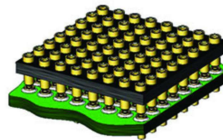

After Soldering

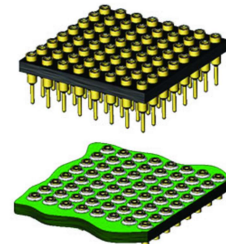

ULTRA LOW PROFILE DIP

Before Soldering

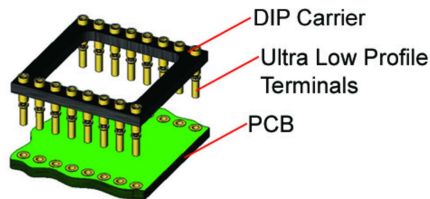

During Soldering

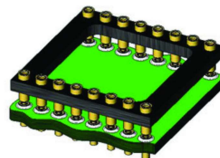

After Soldering

